

2004.5-2005 LLY DURAMAX
ROTARY SWITCH

USER MANUAL

Disclaimer

- By installing this product onto your vehicle, you assume all risk and liability associated with its use.
- GDP Tuning, LLC. is not responsible for misuse of its products. By installing this product, you release GDP Tuning, LLC. of any and all liability associated with its use.
- The purchaser and end user releases, indemnities, discharges and holds harmless GDP Tuning, LLC. from any and all claims, damages, causes of action, injuries, or expenses resulting from or relating to the use or installation of this product that is in violation of the terms and conditions on this page, the product disclaimer, and/or the product installation instructions. GDP Tuning, LLC. will not be liable for any direct, indirect, consequential, exemplary, punitive, statutory, or incidental damages or fines caused by the use or installation of this product.

Caution

Never work on a hot vehicle. Serious injury in the form of burns can result if the vehicle has been in use. Allow vehicle to cool prior to installation. Always wear eye protection when working on or under any vehicle.

1

Notice:

Unplug both batteries before installation.

2004.5-2005 LLY DURAMAX ROTARY SWITCH

GDP410015

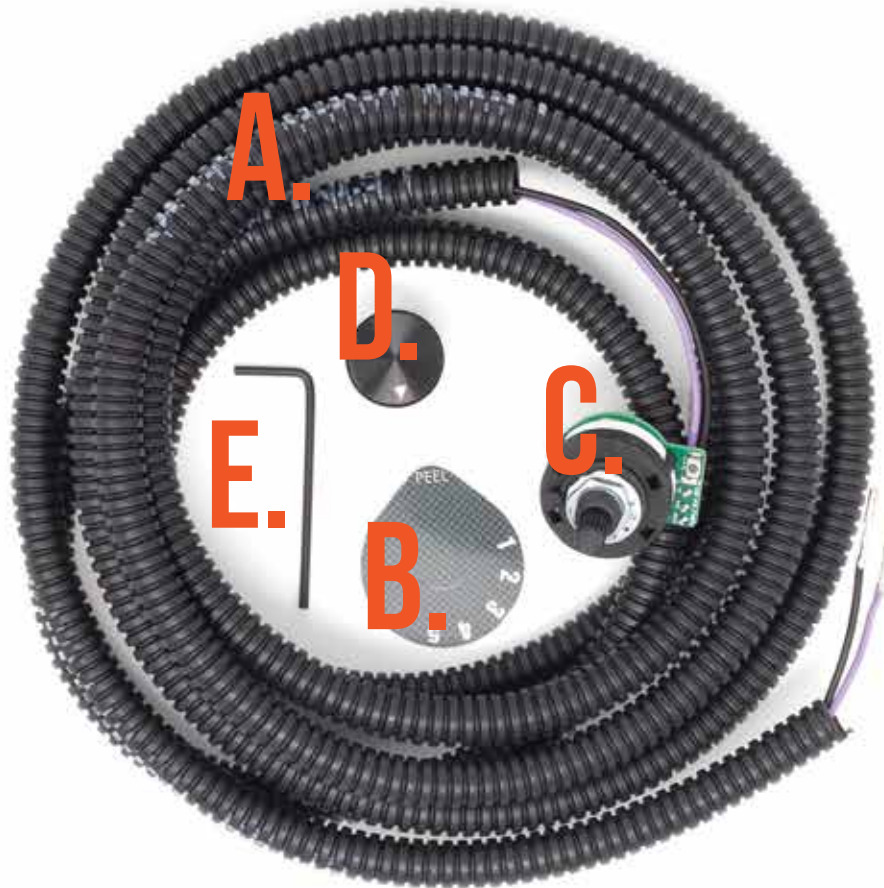

- A. Loomed electrical wires
- B. Dial stickers
- C. Switch control board

- D. Switch knob
- E. Allen Wrench

Step 1

Use C3 grey connector



Step 2

Lift grey lever & detach all 3 plugs



Step 3

Use bottom grey connector



Step 4

Remove pin lock

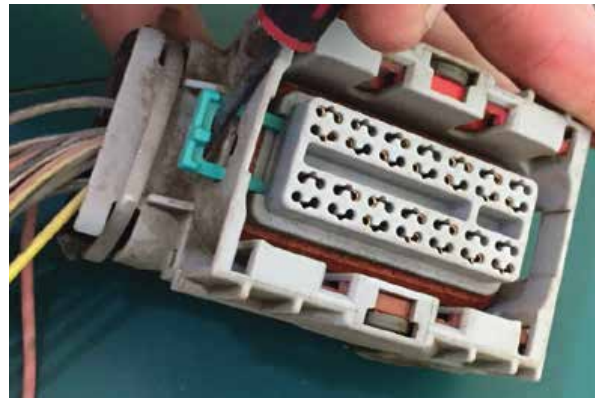

Step 5

Remove black cover, insert flathead screwdriver into unlock clips



Step 6

Remove black cover



Step 7

Top view of connector



Step 8

Locate correct pin locators



Step 9

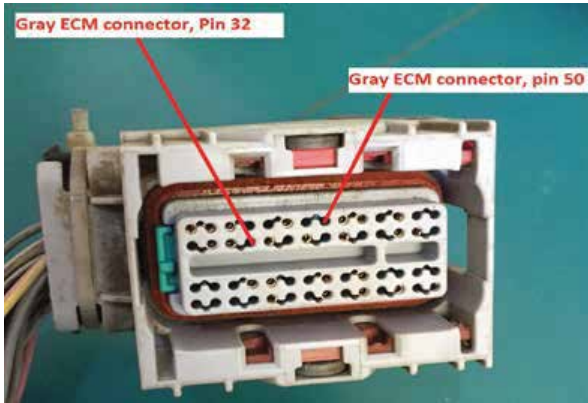

Step 10

Remove pin filler

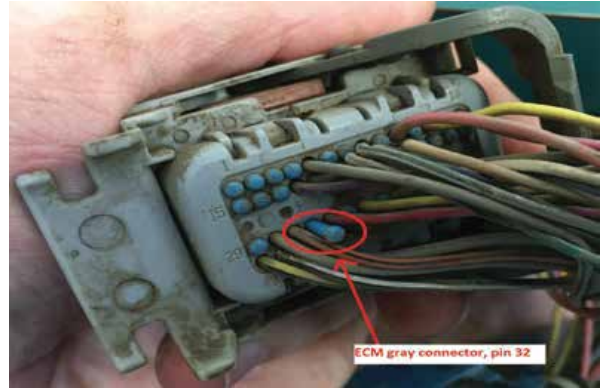

Step 11

Insert pin & wires to latch, reinstall pin lock

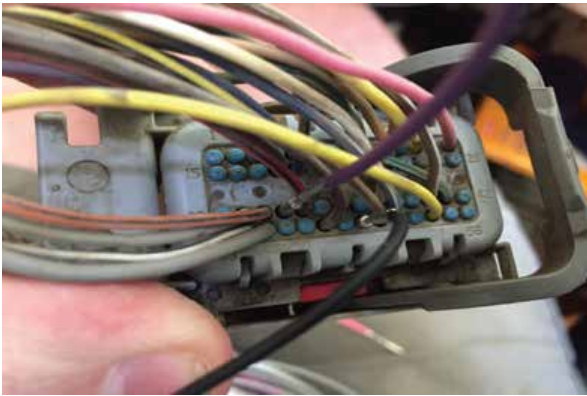

Step 12

Reassemble connectors



Notice:

Proper switch pin position between the 5th and 6th slot



Notice:

Stock Connector

Signal = Grey connector, pin 32
Ground = Grey connector, pin 50

GDP Wires

Signal = Purple
Ground = Black

Troubleshooting:

To troubleshoot your switch, you will need a voltmeter.

Step 1

Set your switch to position 1.

Step 2

Turn key to the run position. (engine off or on)

Step 3

Test the Switch on the fly wire (Purple Wire). These numbers may vary within their specific levels. (i.e. 4.0-4.9 in Position 1) The voltage you should be seeing is:

Step 4

If the readings do not match, please check your connections and pins to make sure they are not bent or broken. As well as, there is no debris stopping the pins from being inserted completely.

Step 5

If the issue persists please call our tech support line for more help. 877-223-5018

LEVEL 1	4.5
LEVEL 2	3.5
LEVEL 3	2.5
LEVEL 4	1.5
LEVEL 5	0.5
HIGH IDLE	5.0